

TYPICAL ELEVATIONS

APPROVAL APPLIES TO SINGLE OR MULTIPLE UNIT INSTALLATIONS

MAX. DESIGN LOAD = + 70 PSF  
- 70 PSF

**SERIES 'SLIMPACT' GLASS WALL SYSTEM**

THIS PRODUCT HAS BEEN DESIGNED AND TESTED TO COMPLY WITH THE REQUIREMENTS OF THE 2014 (5TH EDITION)/2017 (6TH EDITION) FLORIDA BUILDING CODE INCLUDING HIGH VELOCITY HURRICANE ZONE (HVHZ).

1BY OR 2BY WOOD BUCKS & BUCK FASTENERS BY OTHERS, MUST BE DESIGNED AND INSTALLED ADEQUATELY TO TRANSFER APPLIED PRODUCT LOADS TO THE BUILDING STRUCTURE.

ANCHORS SHALL BE CORROSION RESISTANT, SPACED AS SHOWN ON DETAILS AND INSTALLED PER MANUF'S INSTRUCTIONS. SPECIFIED EMBEDMENT TO BASE MATERIAL SHALL BE BEYOND WALL DRESSING OR STUCCO.

A LOAD DURATION INCREASE IS USED IN DESIGN OF ANCHORS INTO WOOD ONLY. ALL SHIMS TO BE HIGH IMPACT, NON-METALLIC AND NON-COMPRESSIBLE.

MATERIALS INCLUDING BUT NOT LIMITED TO STEEL/METAL SCREWS, THAT COME INTO CONTACT WITH OTHER DISSIMILAR MATERIALS SHALL MEET THE REQUIREMENTS OF THE 2014/2017 FLORIDA BLDG. CODE & ADOPTED STANDARDS.

THIS PRODUCT APPROVAL IS GENERIC AND DOES NOT PROVIDE INFORMATION FOR A SITE SPECIFIC PROJECT, i.e. LIFE SAFETY OF THIS PRODUCT, ADEQUACY OF STRUCTURE RECEIVING THIS PRODUCT AND SEALING AROUND OPENING FOR WATER INFILTRATION RESISTANCE ETC. CONDITIONS NOT SHOWN IN THIS DRAWING ARE TO BE ANALYZED SEPARATELY, AND TO BE REVIEWED BY BUILDING OFFICIAL.

MANUFACTURER'S LABEL SHALL BE LOCATED ON A READILY VISIBLE LOCATION IN ACCORDANCE WITH SECTION 1709.9.3 OF FLORIDA BUILDING CODE. LABELING TO COMPLY WITH SECTION 1709.9.2.

| ANCHOR TYPE | ANCHOR SPACING INCHES |      |        |
|-------------|-----------------------|------|--------|
|             | HEAD                  | SILL | JAMBS  |
| A           | 4"                    | 4"   | 6-3/4" |
| B           | 8                     | 8    | 8      |
| C           | -                     | -    | 6-3/4  |
| D           | 8                     | 8    | 8      |

MAX. FRAME HEIGHT = 124 IN.  
MAX. GLASS HEIGHT = 121-1/2 IN.  
MAX. D.L.O. HEIGHT = 120-1/8 IN.  
MAX. GLASS/D.L.O. WIDTH = 84 IN.

THIS SYSTEM IS RATED FOR LARGE & SMALL MISSILE IMPACT. SHUTTERS ARE NOT REQUIRED.

FL #25673

- A- CONTRACTOR TO BE RESPONSIBLE FOR THE SELECTION, PURCHASE AND INSTALLATION OF THIS PRODUCT BASED ON THIS PRODUCT EVALUATION PROVIDED HE/SHE DOES NOT DEVIATE FROM THE CONDITIONS DETAILED ON THIS DOCUMENT.
- B- THIS PRODUCT EVALUATION DOCUMENT WILL BE CONSIDERED INVALID IF ALTERED BY ANY MEANS.
- C- SITE SPECIFIC PROJECTS SHALL BE PREPARED BY A FLORIDA REGISTERED ENGINEER OR ARCHITECT WHICH WILL BECOME THE ENGINEER OF RECORD (E.O.R.) FOR THE PROJECT AND WHO WILL BE RESPONSIBLE FOR THE PROPER USE OF THE P.E.D. ENGINEER OF RECORD, ACTING AS A DELEGATED ENGINEER TO THE P.E.D. ENGINEER SHALL SUBMIT TO THIS LATTER THE SITE SPECIFIC DRAWINGS FOR REVIEW.
- D- THIS P.E.D. SHALL BEAR THE DATE AND ORIGINAL SEAL AND SIGNATURE OF THE PROFESSIONAL ENGINEER OF RECORD THAT PREPARED IT.

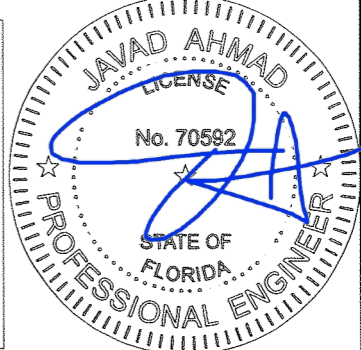

**af c**  
AL-FAROOQ CORPORATION  
ENGINEERS & PRODUCT DEVELOPMENT  
9360 SUNSET DRIVE, SUITE 220  
MIAMI, FLORIDA 33173 (C.A.N. 3538)  
TEL. (305) 264-8100 FAX. (305) 262-6978  
COMP-ANL/W17-104FGT

SERIES 'SLIMPACT' SSG GLASS WALL SYSTEM (L.M.I.)  
**Faour Glass Technologies**  
5119 West Knox Street  
Tampa, FL 33634  
Tel. (813) 884-3297 Fax. (-)

|             |          |          |            |             |
|-------------|----------|----------|------------|-------------|
| revisions:  | no       | date     | by         | description |
|             |          |          |            |             |
| date:       | 11-08-17 | scale:   | 3/8"=1'-0" |             |
| dr. by:     | TARIQ    | chk. by: |            |             |
| drawing no. | W17-104  |          |            |             |
| sheet       | 1 of 4   |          |            |             |

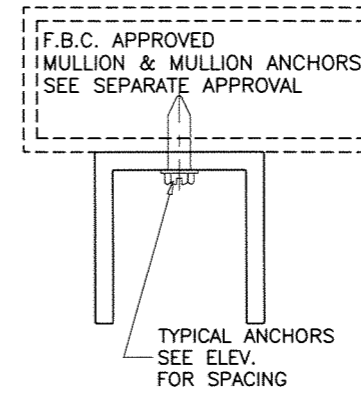
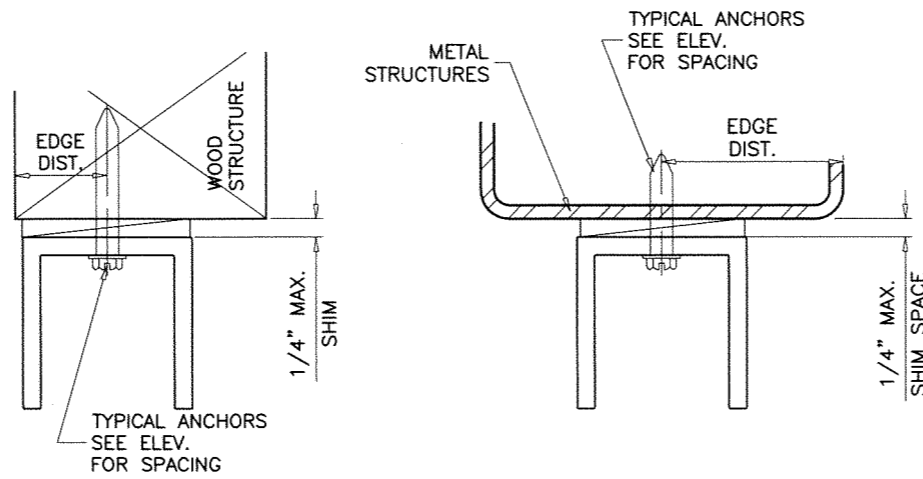
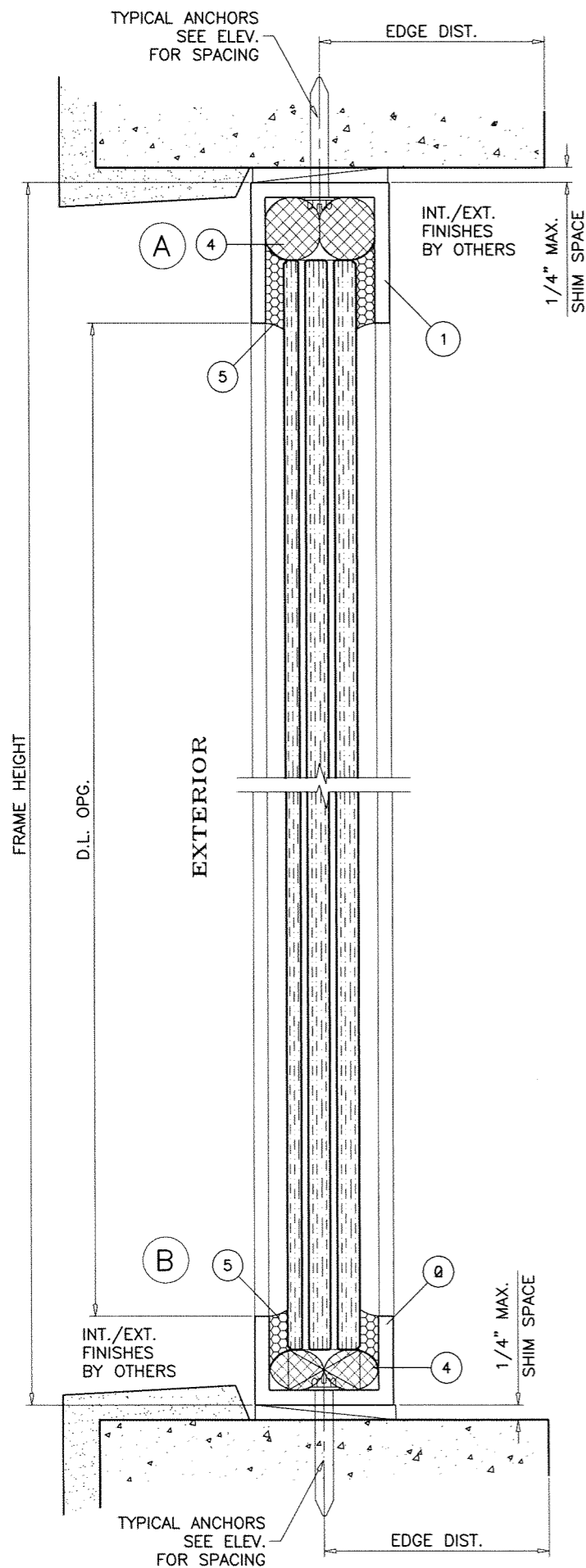

WOOD BUCKS AND METAL STRUCTURE NOT BY FAOUR GLASS MUST SUSTAIN LOADS IMPOSED BY GLAZING SYSTEM AND TRANSFER THEM TO THE BUILDING STRUCTURE.

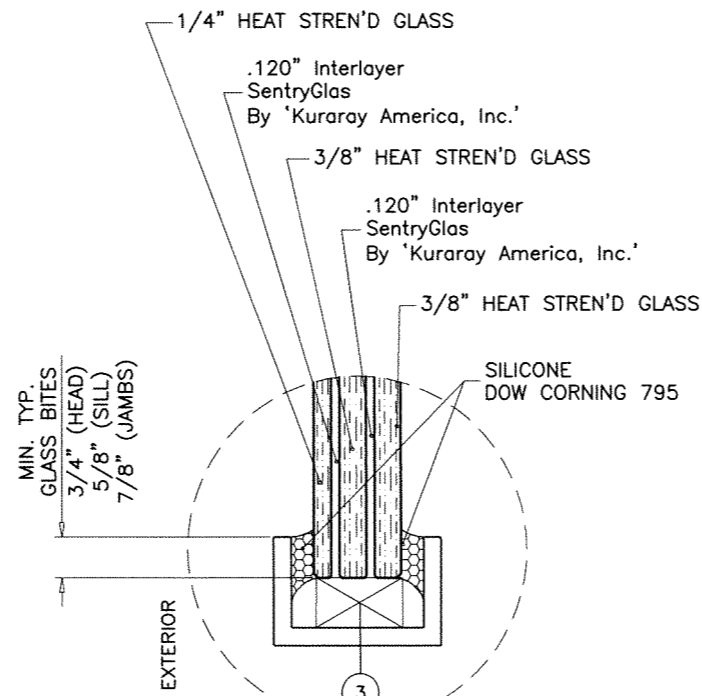

**GLAZING DETAIL**  
1-1/4" OVERALL LAM. GLASS

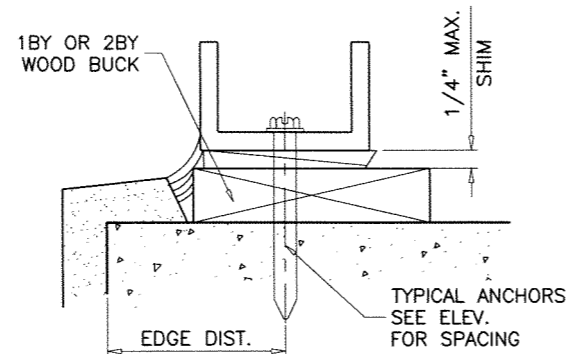

**TYPICAL ANCHORS:** SEE ELEV. FOR SPACING

- ANCHOR 'A' - 5/16" DIA. ULTRACON BY 'ELCO' (Fu=177 KSI, Fy=155 KSI) INTO 2BY WOOD STRUCTURES  
1-7/8" MIN. PENETRATION INTO WOOD (HEAD/SILL/JAMBS)  
THRU 1BY OR 2BY BUCKS INTO CONC. OR BLOCKS  
1-1/4" MIN. EMBED INTO CONCRETE (HEAD/SILL/JAMBS)  
1-3/4" MIN. EMBED INTO GROUT FILLED BLOCKS (JAMBS)
- ANCHOR 'B' - 5/16" DIA. ULTRACON BY 'ELCO' (Fu=177 KSI, Fy=155 KSI) DIRECTLY INTO CONCRETE  
1-3/4" MIN. EMBED INTO CONCRETE (HEAD/SILL/JAMBS)
- ANCHOR 'C' - 5/16" DIA. ULTRACON BY 'ELCO' (Fu=177 KSI, Fy=155 KSI) DIRECTLY INTO BLOCKS  
1-3/4" MIN. EMBED INTO GROUT FILLED BLOCKS (JAMBS)
- ANCHOR 'D' - 5/16" DIA. TEKS OR SELF DRILLING SCREWS (GRADE 5 CRS) INTO F.B.C. APPROVED MULLIONS OR INTO METAL STRUCTURES (HEAD/SILL/JAMBS)  
(3) THREADS MIN. PENETRATION BEYOND SUBSTRATE  
ALUMINUM: 1/8" THK. MIN. (6063-T5 MIN.)  
STEEL: 1/8" THK. MIN. (Fy = 36 KSI MIN.)  
(STEEL IN CONTACT WITH ALUMINUM TO BE PLATED OR PAINTED)

**TYPICAL EDGE DISTANCE**

- INTO CONC. OR BLOCKS = 2-1/2" MIN.
- INTO WOOD STRUCTURE = 1-1/4" MIN.
- INTO METAL STRUCTURE = 3/4" MIN.

- WOOD AT HEAD, SILL OR JAMBS SG = 0.55 MIN.
- CONCRETE AT HEAD, SILL OR JAMBS f'c = 3000 PSI MIN.
- C-90 HOLLOW/FILLED BLOCK AT JAMBS f'm = 2000 PSI MIN.

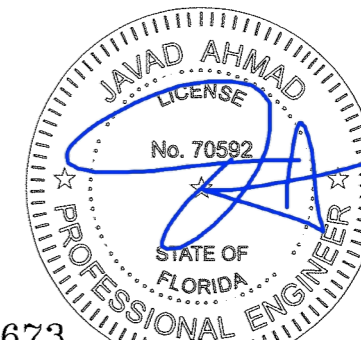

FL #25673

**afc**  
**AL-FAROOQ CORPORATION**  
ENGINEERS & PRODUCT DEVELOPMENT  
9360 SUNSET DRIVE, SUITE 220  
MIAMI, FLORIDA 33173 (C.A.N. 3538)  
TEL (305) 264-8100 FAX (305) 262-6978  
COMP-ANL\W17-104FGT

SERIES 'SLIMPACT' SSG GLASS WALL SYSTEM (L.M.I.)  
**Faour Glass Technologies**  
5119 West Knox Street  
Tampa, FL 33634  
Tel. (813) 884-3297 Fax. (-)

| revisions:  | no        | date | by | description |
|-------------|-----------|------|----|-------------|
| date:       | 11-08-17  |      |    |             |
| scale:      | 3/8" = 1" |      |    |             |
| dr. by:     | TARIQ     |      |    |             |
| chk. by:    |           |      |    |             |
| drawing no. | W17-104   |      |    |             |
| sheet       | 2 of 4    |      |    |             |

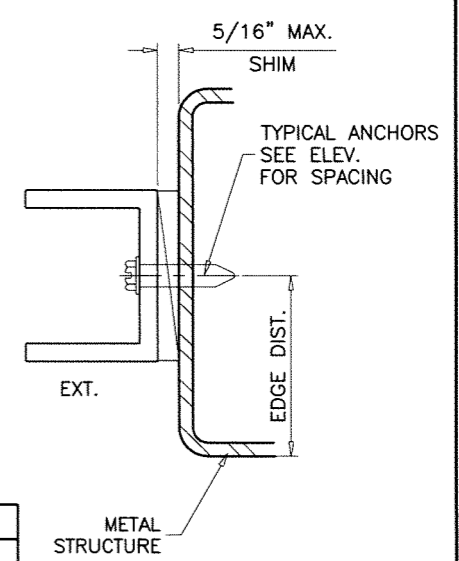
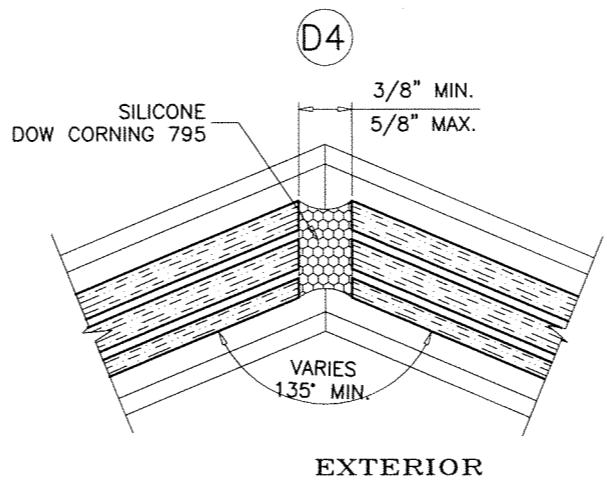
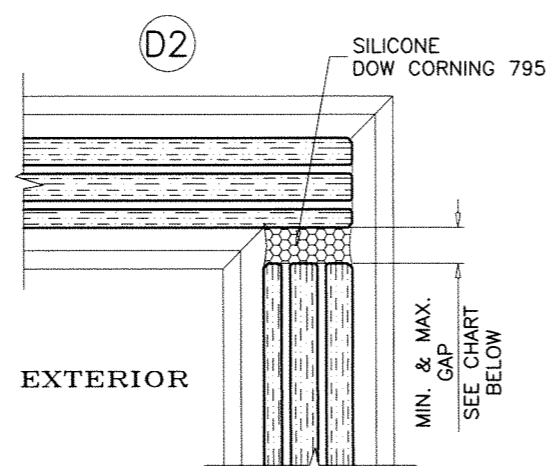
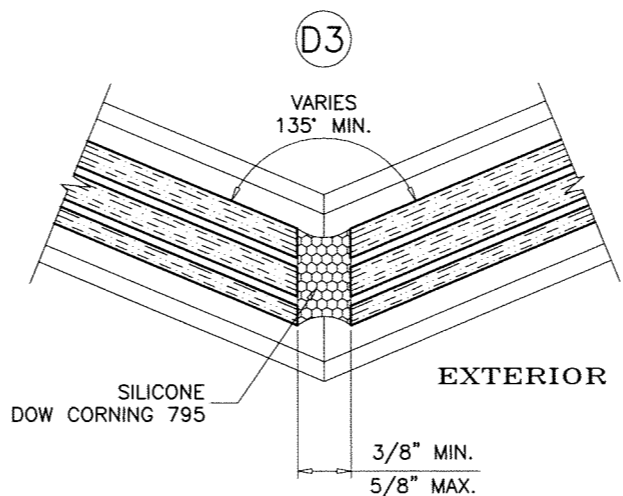
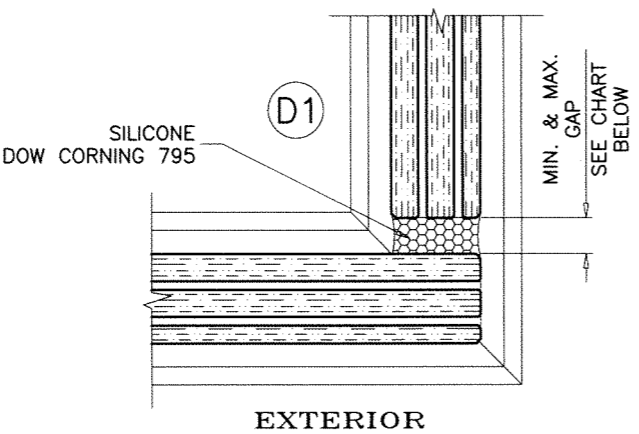
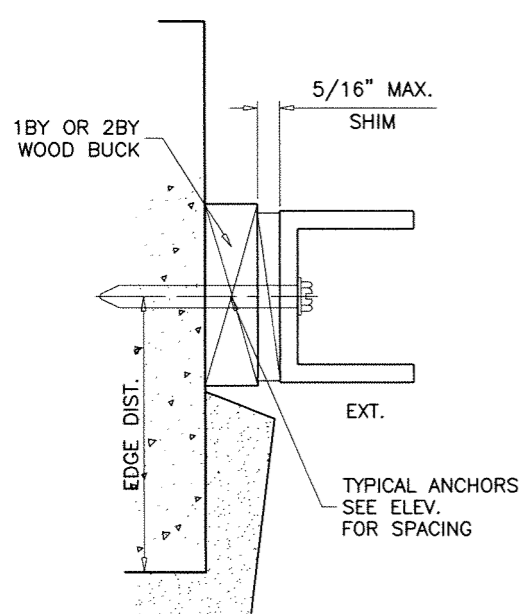
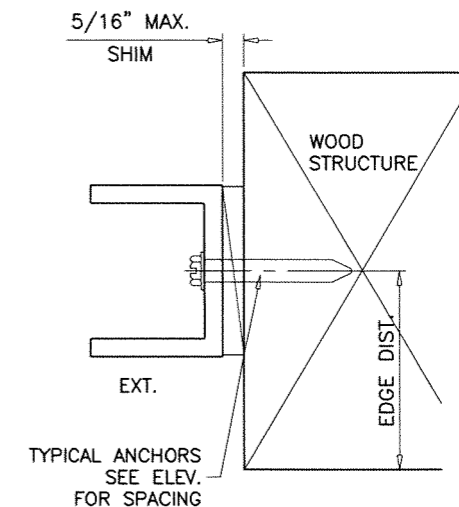
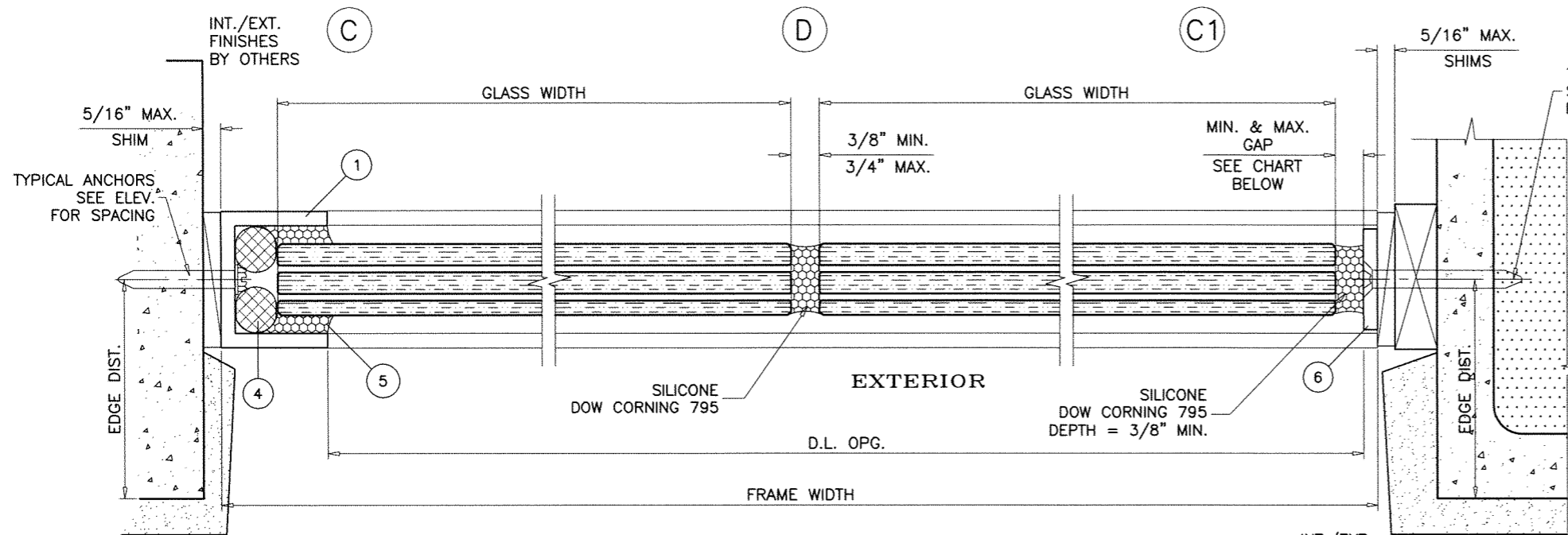

| MAX. FRAME HEIGHT | GAP   |      |
|-------------------|-------|------|
|                   | MIN.  | MAX. |
| 60"               | 5/16" | 3/4" |
| 76"               | 3/8"  | 3/4" |
| 100"              | 1/2"  | 3/4" |
| 124"              | 5/8"  | 3/4" |

NOTE:  
 MAX. MOVEMENT CONSIDERED=50% STRETCH.  
 PLEASE REFER TO SEALANT MANUFACTURER'S DATA AND APPLICATION MANUAL FOR COMPATIBILITY OF SEALANT TO SUBSTRATE & WINDOWALL MATERIAL/FINISH AND COMPLIANCE FOR WARRANTY.  
 REFER TO ACI-117-10 FOR CONSTRUCTION TOLERANCES.  
 ALTERNATE SEALANTS AT JAMB GAPS CAN BE DESIGNED BY ENGINEER OF RECORD BASED ON MANUFACTURER GUIDE LINES.

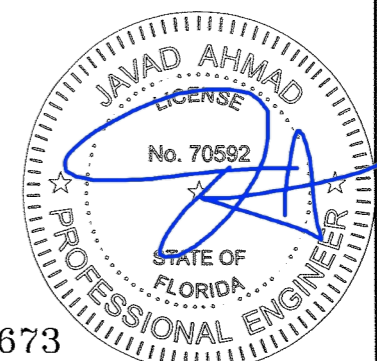

FL #25673

**af c**  
**AL-FAROOQ CORPORATION**  
 ENGINEERS & PRODUCT DEVELOPMENT  
 9360 SUNSET DRIVE, SUITE 220 (C.A.N. 3538)  
 MIAMI, FLORIDA 33173  
 TEL. (305) 264-8100 FAX. (305) 262-6978  
 COMP-ANL W17-104FGT

SERIES 'SLIMPACT' SSG GLASS WALL SYSTEM (L.M.I.)  
**Faour Glass Technologies**  
 5119 West Knox Street  
 Tampa, FL. 33634  
 Tel. (813) 884-3297 Fax. (-)

| revisions: | no | date | description |
|------------|----|------|-------------|
|            |    |      |             |
|            |    |      |             |
|            |    |      |             |

date: 1-08-17  
 scale: 3/8" = 1"  
 dr. by: TARIQ  
 chk. by:

drawing no.  
**W17-104**

sheet 3 of 4

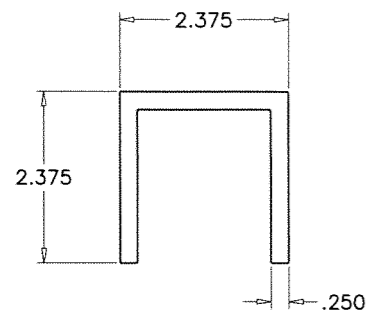

1 TOP/SIDE CHANNEL

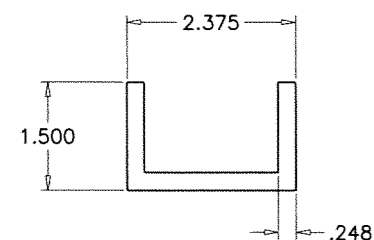

2 BOTTOM CHANNEL

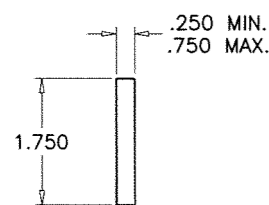

6 JAMB BAR

| ITEM # | PART # | REQD.    | DESCRIPTION                  | MATERIAL | MANF./SUPPLIER/REMARKS |
|--------|--------|----------|------------------------------|----------|------------------------|
| 1      | -      | AS REQD. | TOP/SIDE CHANNEL             | 6063-T4  | -                      |
| 2      | -      | AS REQD. | BOTTOM CHANNEL               | 6063-T4  | -                      |
| 3      | -      | 2/ LITE  | SETTING BLOCKS AT 1/4 POINTS | EPDM     | DUROMETER 80±5 SHORE A |
| 4      | -      | AS REQD. | 3/8" DIA. BACKER ROD         | FOAM     | -                      |
| 5      | 795    | AS REQD. | GLAZING COMPOUND             | SILICONE | DOW CORNING            |
| 6      | -      | AS REQD. | JAMB BAR                     | 6063-T4  | -                      |

**SEALANT:**

ALL FRAME JOINTS SQUARE-CUT AND BUTTED,  
SEALED WITH DOW CORNING 123 SILICONE SEAL TAPE.

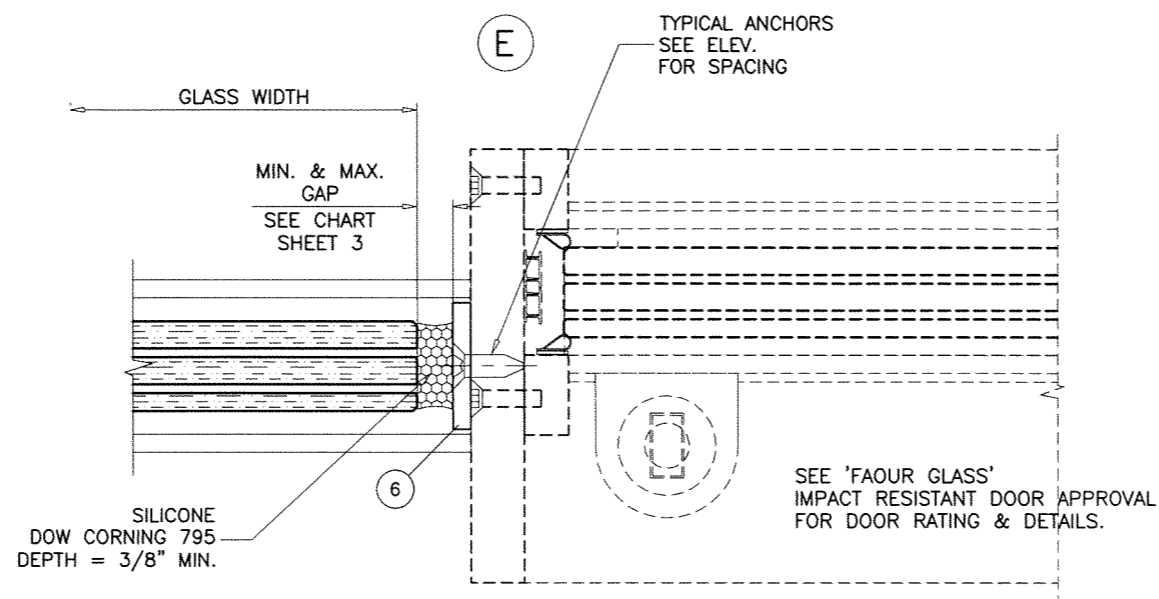

SEE SEPARATE APPROVAL FOR DESIGN LOAD  
CAPACITY OF DOOR AND DOOR ANCHORS.

LOWER VALUES FROM DOOR APPROVAL  
OR GLASS WALL SYSTEM CAPACITY WILL  
APPLY TO ENTIRE SYSTEM.

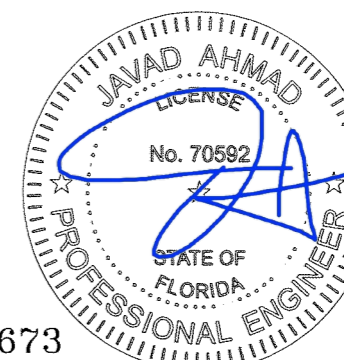

FL #25673

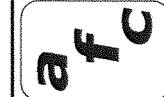

**AL-FAROQ CORPORATION**  
ENGINEERS & PRODUCT DEVELOPMENT  
9360 SUNSET DRIVE, SUITE 220  
MIAMI, FLORIDA 33173  
TEL. (305) 262-6978  
FAX. (305) 264-8100  
(C.A.N. 3538)

SERIES 'SLIMPACT' SSG GLASS WALL SYSTEM (L.M.I.)  
**Faour Glass Technologies**  
5119 West Knox Street  
Tampa, FL 33634  
Tel. (813) 884-3297 Fax. (-)

| revisions: | no | date | by | description |
|------------|----|------|----|-------------|
|            |    |      |    |             |

date: 11-08-17  
scale: 3/8" = 1"  
dr. by: TARIQ  
chk. by:

drawing no.  
**W17-104**  
sheet 4 of 4

COMP-ANL\W17-104FGT